



# **PROJECT PREPARATION GUIDE**

with reference to the set-up  
standard A-440.4 / GCR fenestration

## SCOPE

- Any references to the Code are to the Quebec Construction Code, Chapter I - Building, and the National Building Code of Canada 2010 (amended) (hereinafter referred to as the Code) and are therefore mandatory for buildings subject to it.
- "The minimum required performance level of windows, doors and skylights shall be R performance class." (See 11.1.2). [Extract of the Code, paragraph 9.7.4.3. 3)] 1

Please note that the notes with the indication \*GCR appearing in the following document, apply only to projects governed by the Residential Construction Warranty



## PREREQUISITE OF THE INSTALLATION

- Before the installation of the window frames can begin, the bracing of the walls and roof must be completed.
  - Bracing can be provided by walls (vertical bracing) or plates (horizontal bracing) made of reinforced concrete, masonry, wood or corrugated sheet metal; or by wood or steel lattices.
- The waterproofing of the roof must be completed (shingles/ roofing)
- Installation of the exterior cladding membrane (Tyvek, black paper, blue skin type membrane (commercial) must be completed.
- The sills of the bay must have a humidity level of less than 19%.

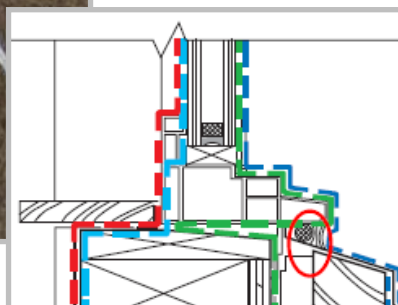
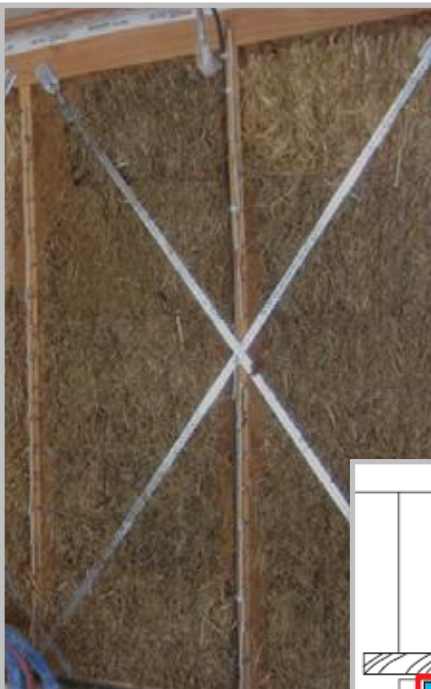

**NOTE:** Fabelta requests that the bay width be between 31.75 mm (1-1/4 in.) and 38 mm (1 1/2 in.) and the height between 31.75 mm (1-1/4 in.) and 44 mm (1 3/4 in.) for ease of alignment.

## POSITIONING

- Ensure that the fenestration system is aligned within the insulation point it passes through.
- Windows, doors and skylights must be installed in accordance with the standard *CAN/CSA-A440.4 4 and Section 9.27. of Code 1.*

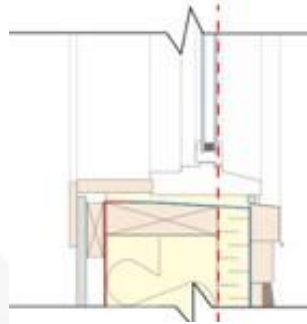

Maximum alignment of the outer side of the glass panels to the exterior

There must be insulation with a minimum thermal resistance of RSI 0.70 in front of the external axis of the thermos.

\*Requirement of the **GCR**, not a requirement of A440-4

*[Reference, article 2.3.2.1, Novoclimat technical requirements, Multi-dwelling units and small buildings] 10*

## MATERIALS REQUIREMENTS

- Window frames and sashes must have thermal breaks.
- The maximum overall thermal transmittance (U-value) and minimum energy performance (ER) must comply with the requirements of Section 11 of the Code. *(RE 21 min UG max 1.8)*
- Factory-made or pre-assembled windows, doors and skylights and their installation shall comply with Code 1, to the standards *AAMA/WDMA/CSA 101/I.S.2/A440 2 and CSA A440S13.*
- \*\*\* csa certification \*\*\*

The Contractor shall provide the performance class and CPof the product

## WEDGES

- Supporting wedges for windows, doors and skylights can be made of treated plywood. *[Reference to the Code, paragraph 9.7.6.1. 1)a]* 1
- "Cedar shingles used as shims shall conform to CSA O118.1 or O118.2. Only pre-cut shims shall be used. The use of cuts is prohibited." *[Extract from the standard CAN/CSA-A440.4, article 4.10.2]* 4

## INSULATORS

- Use insulating materials such as:
  - one or two-component polyurethane foam;
  - Mineral fiber;
  - Fiberglass.

*[Reference to the standard CAN/CSA-A440.4, article 4.7.1 and 4.7.2]* 4

## SEALERS

- The sealants used shall adhere to and be compatible with the substrates to which they are applied.
- Sealants shall be of the type:
  - non-hardening for exterior use; and
  - Age resistant.

## \*GCR

A closed cell backer rod should be installed between the window, door or skylight frame and the siding. The sealant shall:

- be driven into the borehole in accordance with the sealant manufacturer's recommendations;
- b) have a diameter 30 to 50% larger than the borehole, so that it must be compressed into it.

It may be necessary to use different thicknesses of backer rod because the width of the opening between the opening and the window frame may vary;

- be of continuous length in order to avoid joints in the material; and
- not be perforated during installation.

*[Reference to the standard CAN/CSA-A440.4, article 8.7.2]*

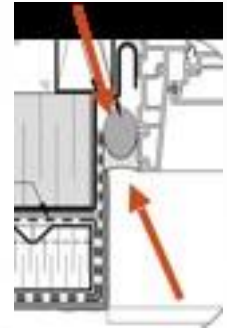

## LEVEL

- A frame where the sill is horizontal shall be considered at level when the vertical deviation measured from one end to the other is not more than 2 mm ( $\pm 1/16''$ ) regardless of its length. \*Article 6.4.1.2 of the standard CAN/CSA-A440.4

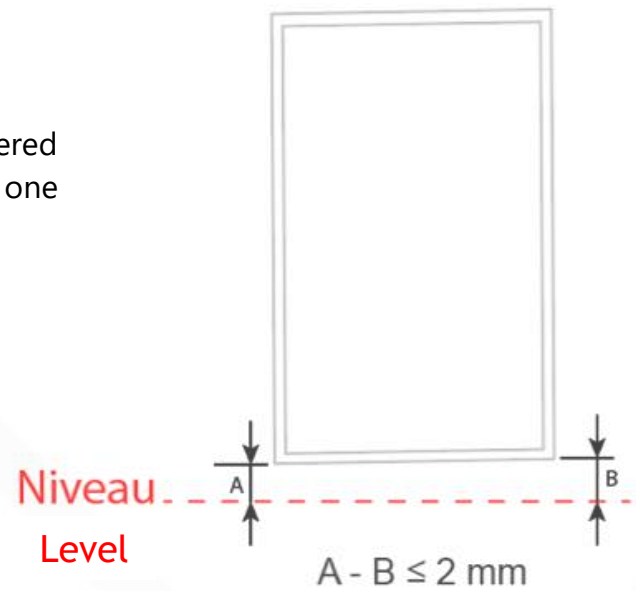

## SQUARE

- A window frame shall be considered square if the total height and width of the frame measured at mid-span is equal to the average height or width  $\pm 1 \text{ mm}$  ( $\pm 1/32''$ )
- The difference between the two diagonals is less than or equal to 2 mm ( $\pm 1/16''$ ) for a frame with an outside perimeter equal to or less than 4 meters or the difference between the two diagonals is less than or equal to 3 mm for a frame with an outside perimeter greater than or equal to 4 meters \*Article 6.4.1.2 of the standard CAN/CSA-A440.4

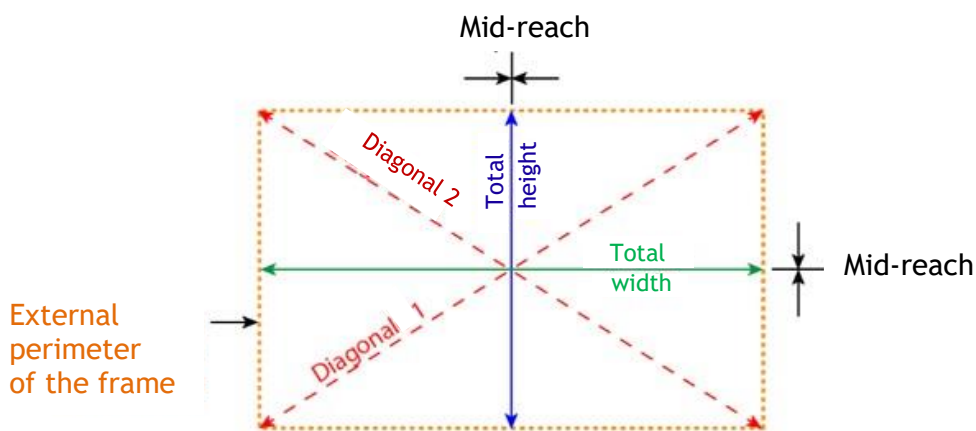

## PLUMB LINE

- A window frame shall be considered plumb if the vertical offset in the plane perpendicular to the face of the head member from the sill or the support is less than or equal to 2 mm and water will not be retained on the sill or its support.<sup>4</sup> (See Figure 11.3.1.3) *Article 6.4.1.2 of the standard CAN/CSA-A440.4*

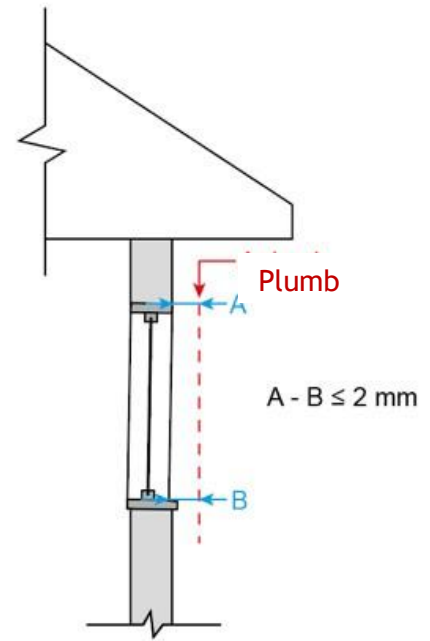

## OPENING

- The bay width must be between 19 mm (3/4") and 38 mm (1 1/2 in.) wider than the width of the window frame.
- A minimum of 9.5 mm (3/8") and a maximum of 19 mm (3/4") should be left open on both sides of the frame.
- The bay height should be between 25 mm (1") and 44 mm (1 3/4") higher than the window frame height.
- A minimum of 12.5 mm (1/2 in.) and a maximum of 22 mm (7/8 in.) should be left open at the top and bottom of the frame.
- The window must be centered in the bay so that the daylight is evenly distributed on each side of the window to within  $\pm 3$  mm (1/8") apart.<sup>4</sup> (See figure 11.3.2.1) *[Reference to the standard CAN/CSA-A440.4, article 6.4.2.2]*<sup>4</sup>

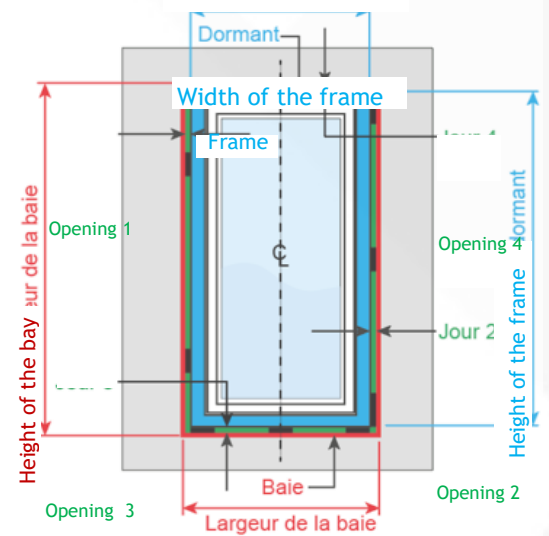

Bay

Width of the bay

**Note:** Fabelta requests that the bay width be between 31.75 mm (1-1/4 in.) and 38 mm (1 1/2 in.) and the height between 31.75 mm (1-1/4 in.) and 44 mm (1 3/4 in.) for ease of alignment.

## MANAGEMENT OF SETBACKS

- For wood-frame buildings with masonry cladding, allow for settlement due to the shrinkage of the wood structural components.
- Therefore, the following clearances should be provided:
  - 6 to 12 mm (+- 1/4" - 1/2") between the jamb and the masonry;
  - a minimum of 9.5 mm between the window or door sill and the masonry (sill) on the first floor; and
  - at least 25 mm between the window or door sill and the masonry (sill) on the second floor. *[Reference to the standard CAN/CSA-A440.4, articles 6.4.2.2 and 6.4.2.3]*
- "Greater clearance is required on upper floors because the effect of framing settlement is cumulative. Above two floors, it is necessary to conduct an analysis for each building to determine the required clearance."  
*[Extract of the standard CAN/CSA-A440.4, articles 6.4.2.2 and 6.4.2.3]*

**NOTE** It should be noted that the shrinkage management clearances in Chapters 8 - Carpentry and 21 - Masonry are lower than those in CAN/CSA-A440.4 and are best practices for buildings not subject to the existing Code.

- The minimum clearances for a 3-floor building in Chapters 8 and 21 are:
  - 4.1 mm on the second floor
  - 8.2 mm on the second floor;
  - 12.3 mm on the third floor.

See Chapter 8 - Timber Framing for more information)

## ADJUSTMENT

- Follow the written instructions of the manufacturer.
- Install shims at regular intervals on the bottom and sides of window and door frames.
- A shim should be installed at each fastener. (screwing)
- Unless otherwise specified by the manufacturer, do not install shims at the headrail to avoid load transfer from the structure to the window or door frame.
- For a fixed window, the shims under the window frame sill should be aligned with the shims used to support the glazing

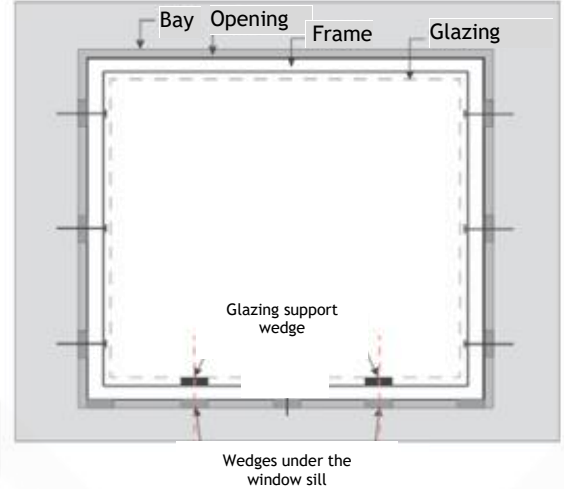

\*\*\* Thermos delivered separately marked wedges when glazing\*\*\*

See Figures 1 to 13 in CAN/CSA-A440.4 for complete shimming recommendations

## METHOD

### ANCHORING

- Follow the manufacturer's written instructions. (pre-drilled holes/clips)
- See figures 1 to 13 of CAN/CSA-A440.4 for anchoring recommendations (positioning and spacing) depending on the type of window or door, frame material and size.
- Ensure that the strength of the fixed window installed over a stairway and not protected by a guardrail meets the lateral load resistance requirements specified in Article 4.1.5.14. of the Code

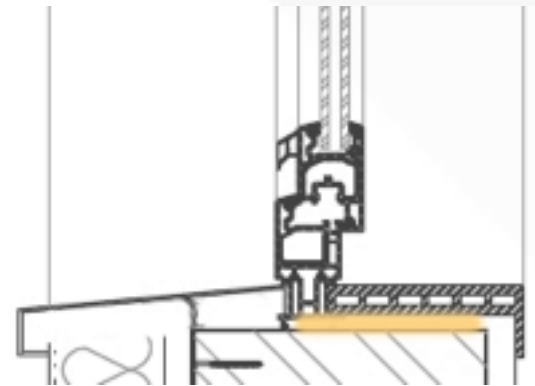

### INSULATOR

- Install the insulation material in the gap at the perimeter of the hole.
- Fill the opening with the insulating product between the product and the opening along the entire perimeter and at least from the inside to the plane of the exterior glazing. [Reference to the standard CAN/CSA-A440.4, article 7.1] 4



# AIR, STEAM AND WATERTIGHTNESS

- "Continuity must be maintained between the window, door or skylight components and the wall to provide protection against rain infiltration, air leaks, thermal transfers and vapor diffusion." [Extract of the standard CAN/CSA-A440.4, article 5.3]
- 1. Determine the exposure level applicable to the building
  - In residential projects in Quebec, the analysis will be handled as high risk. (A2.2 /A440-4)
- 2. Establish a water infiltration control strategy based on the level of exposure;
- 3. Determine, identify and position the essential protective membranes (tyvek/ black paper/ polythene) of the composition of the wall in which the window is to be installed;
- 4. Provide a design that will ensure the continuity of these essential membranes between the window and the wall.

# FLASHING

"Flashing must be installed over openings in an exterior wall if the vertical distance between the top of the finish joinery and the underside of the eaves is greater than 25% of the horizontal projection of the eaves."

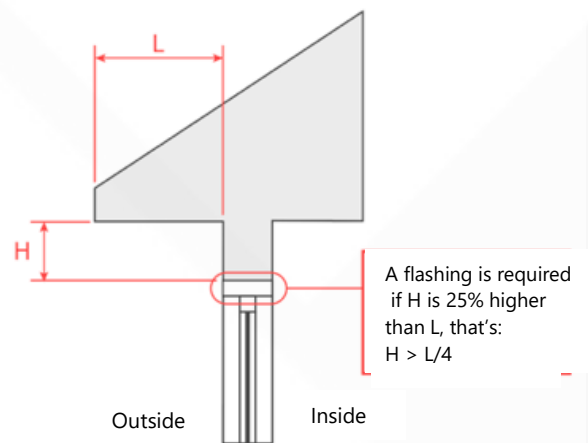

Roof overhang    Level of exposure

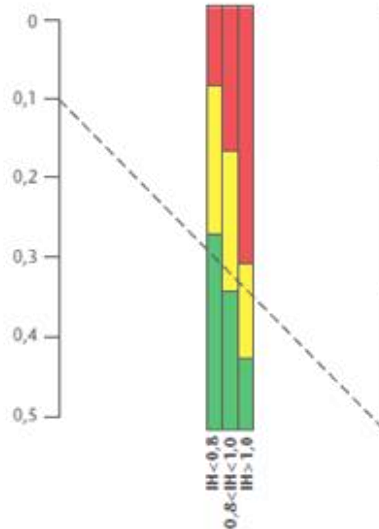

Land

- Open land
  - Exposed to large bodies of water
  - On a hill or near a ravine
  - Surrounded on a large open space
  - High or special building in relation to the landscape or surrounding buildings
- Rural
  - Some large trees
  - A few small buildings or buildings of comparable height
- Suburban
  - Large number of buildings of comparable height
  - Sheltered by mature trees
  - In the center of the city
- Urban agglomerations
  - Surrounded by tall buildings
  - In the center of major cities

Overhang ratio =  $\frac{\text{Width of the exposure}}{\text{Height of the wall}}$

# DRAINAGE OF RAILS AND PROTECTION OF SILLS.

\* In residential projects in Quebec, the analysis will typically be handled as high risk. (A2.2 /A440-4) 10.2.4.1

1

Slope from the outer face of the intermediate coating to at least the inner face of the glazing according to the intended installation

Slope of 6 %  
(0.75 : 12)

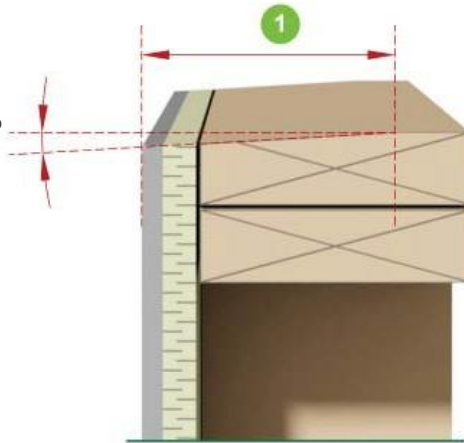

- Sill or exterior sill flashings for windows and doors shall:
  - (a) be a continuous piece, subject to Section 10.2.5.3;
  - (b) have a minimum outward slope of 6% (5.4°);
  - (c) extend at least 6 mm (1/4 in.) beyond the sheathing below and have a drip edge at a 45° angle to the vertical plane of the wall to prevent the backflow of water over the sheathing; and
  - (d) prevent water from entering the walls at the bottom corners of windows and doors.



## \*GCR

The window or door opening must be prepared to receive, collect and direct to the exterior any water that may seep through the sill or threshold or that may collect on the headrail and run down the jamb.

A waterproof membrane or flashing that overlaps, slopes properly and forms a watertight seal should be applied over the sill or threshold and lower corners of the opening so that incidental water is directed:

(a) to the exterior; or

b) where Section 10.3.1(c) does not apply and the wall contains a ventilated air space on the interior side of the cladding, to the exterior of the interior weatherproofing plane in the adjacent wall.



**Note:** Providing drainage on the interior side of the cladding is not a recommended practice unless the durability of the window, door or skylight is greater than that of the assembly in which it is installed, or if the wall has been specifically designed to resist moisture exposure.

\* CAN/CSA-A440.4, articles 10.3.2



## DRAINAGE OF RAILS AND PROTECTION OF SILLS. (CONTINUATION)

- Next, the sill should be protected by a membrane installed in three stages:

### STEP 1 - Lower corner reinforcement

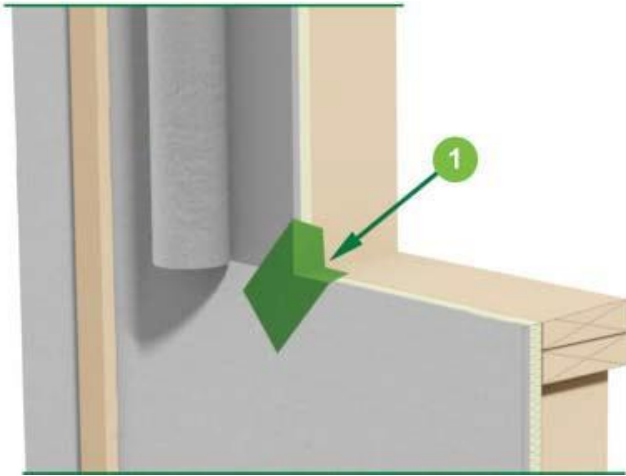

- 1 The bottom corners should be reinforced by installing flexible sealing tapes.

*[Extract from the standard CAN/CSA-A440.4-07, articles 4.6.2]*

### STEP 2 - Membrane on the support rail

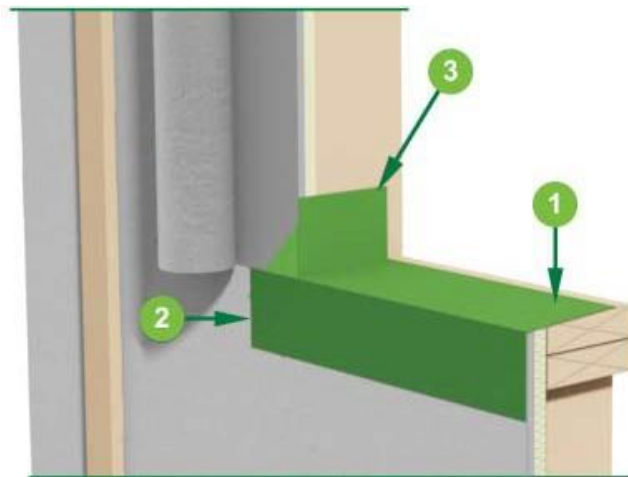

- 1 A membrane should cover the sill from a certain distance before the slope (it is recommended to cover the entire top of the sill)

*[Extract from the standard CAN/CSA-A440.4-07, articles 4.6.1 and 4.6.2]*

- 2 The membrane should overlap the wall sheathing membrane (102 mm (4 in.) is recommended)

- 3 The membrane must be folded into the bay and must extend up the jamb (51 mm (2 in.) recommended)

## DRAINAGE OF RAILS AND PROTECTION OF SILLS (CONTINUATION)

### STEP 3 - Protecting the bottom of the jambs

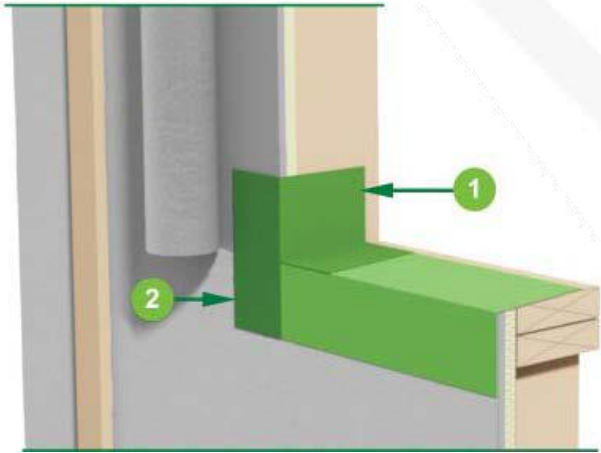

- 1 The base of the jambs should be protected by a membrane covering the fold of the sill plate membrane and the bottom of the jamb in the bay (102 mm (4 in.) height is recommended)  
*[Extract from the standard CAN/CSA-A440.4-07, articles 4.6.1 and 4.6.2]*
- 2 The membrane must cover the intermediate wall covering (102 mm (4 in.) width is recommended)

## MINIMUM JAMB PROTECTION REQUIREMENTS

- The intermediate weather membrane should be folded over the sides of the bay.  
*[Extract from the standard CAN/CSA-A440.4-07, articles 6.1.3]*

### Jamb protections

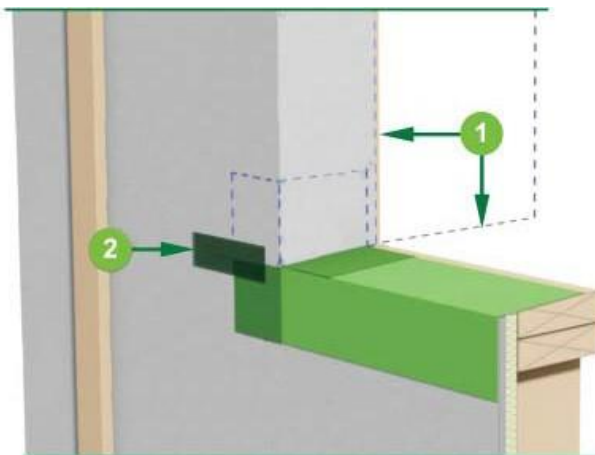

- 1 The intermediate sheathing membrane should be folded back to cover the jamb from bottom to top while covering the membrane reinforcement piece installed in Step 3, Item 1. The excess weather barrier (dotted line) can be cut off.
- 2 Seal the excess from the starting cut with a flexible sealing tape.

# MINIMUM HEADRAIL PROTECTION REQUIREMENTS

- A corner membrane should be added to reinforce the junction between the headrail and the top of the jambs to ensure there are no infiltration points.  
*[Extract from the standard CAN/CSA-A440.4-07, articles 6.1.3]*

## Reinforcements of top corners

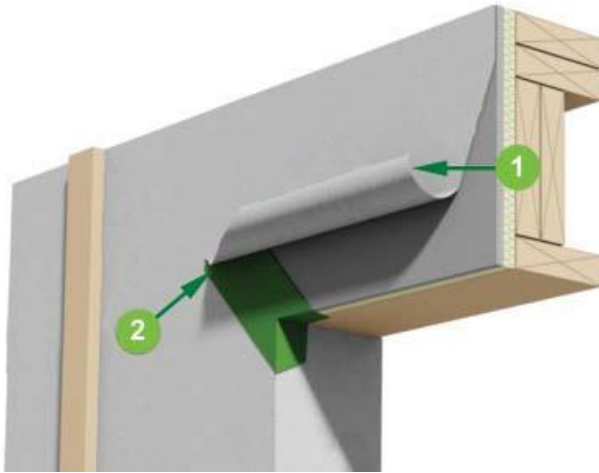

- 1 The intermediate weather membrane should be raised
- 2 The top corners should be reinforced by installing corner membranes. These should be long enough to cover from the cutting point to the edge of the bay and allow for folding back to the inside of the bay

## Protection of the headrail

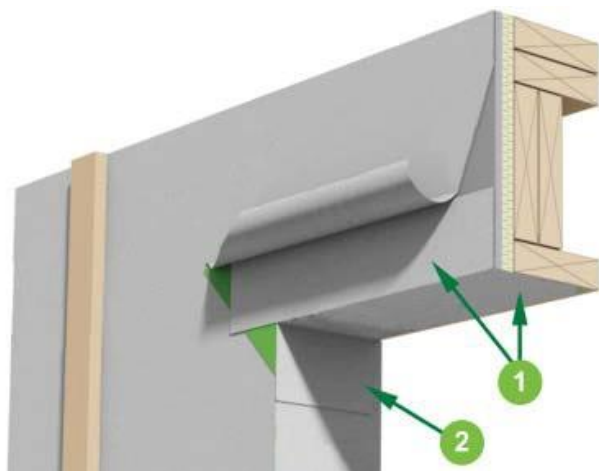

- 1 An additional section of intermediate sheathing membrane should be added, covering the headrail and extending over the corner reinforcement (a minimum vertical overlap of 100 mm (4") is recommended)
- 2 The sheathing membrane must be folded back into the opening and into the bay and should extend down over the jamb (51 mm (2 in.) recommended).

## Quote for preparation of rough opening patio door with lift

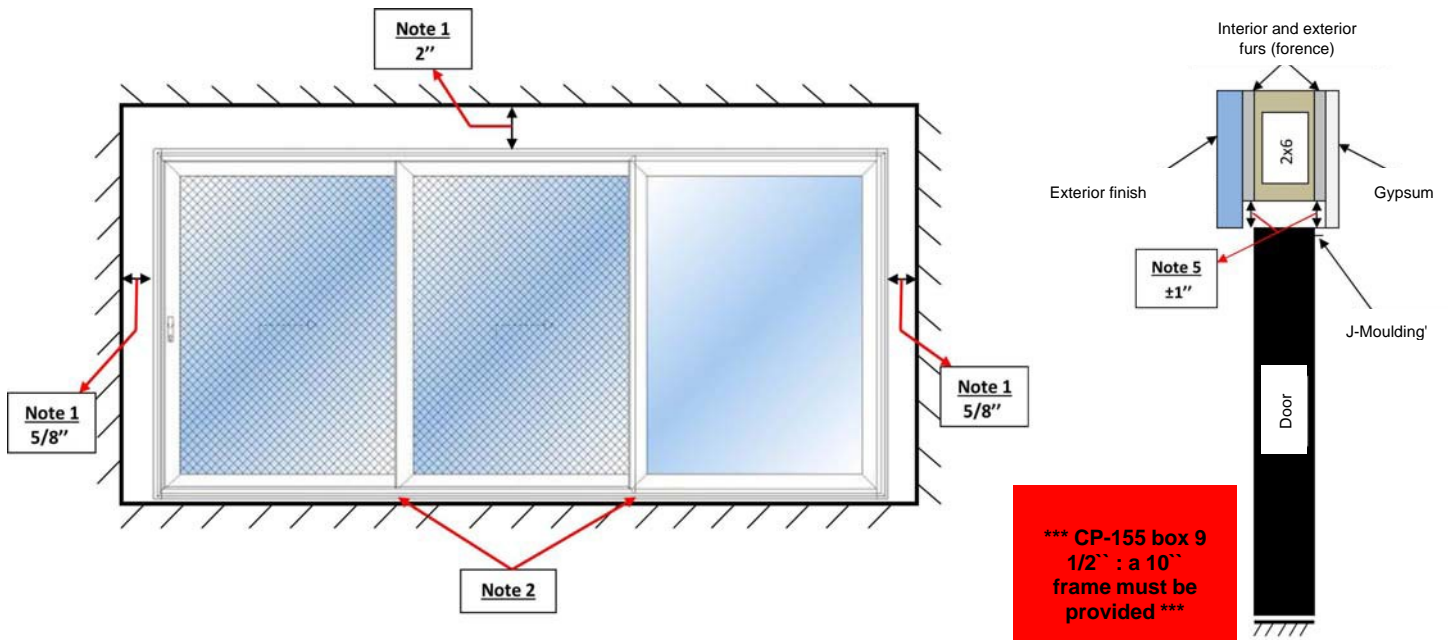

### Note 1: Spacing

A spacing of 2" is required at the top of the door to counteract deflections of the top header. Fabelta is not responsible for the calculation of deflections and materials used as top lintels (LVL, steel beam, ...) that could hinder the proper operation of the door.

A 5/8" spacing is required on each side of the door.

### Note 2: Lower lintel

The bottom lintel must be perfectly level along its entire length and reinforced at the door panel junctions to door panels to counterbalance the spacing of the joists. A tolerance of 1/32` in linearity.

### Note 3: Ventilation

Provide a heat source, other than a radiant floor, with forced air near the door to limit the presence of cold and moisture. We suggest you refer to a ventilation professional for this type of installation.

### Note 4: Indoor finishes (excluding the door 'LOFT')

All outdoor finishes (framing, J-molding, gypsum, ...) must be floating around the door.

### Note 5: Furs

The interior and exterior furs must not be in contact with the door. The required spacing must be +/- 1".

### Note 6: Sill

The sill should be coated with an 8" return on each side.

### Note 7: Handling

The door will be fitted at the construction site and then sealed. If the door is manipulated before the end of the work and it becomes out of adjustment afterwards, a service fee of \$135 will be charged.

### Important note:

**All necessary spacings must be maintained to prevent the cross-members and uprights from expanding or contracting due to temperature changes.**

*This preparation estimate is specific to the lift-up patio door since this product requires a different preparation than other fenestration systems.*

*You should consult the Building Code installation standard for the preparation of your other openings on your project*

# Typical Reynaers CP-155 patio door installation details

**\*IMPORTANT:** If the patio door has three tracks, the wall must be 2 x 10, instead of 2 x 6, or with an equivalent depth (to ensure the proper positioning of the door).

